

# Sterling II - Fluorescent Luminaires (Ex n)

## ATEX, IECEX

### INSTALLATION, OPERATION AND MAINTENANCE INSTRUCTIONS

#### Standard, Stainless Steel, and Emergency Models

**Important:** Please read these instructions carefully before installing or maintaining this equipment. Good electrical practices should be followed at all times and this data should be used as a guide only.

**Technical Drawing:**

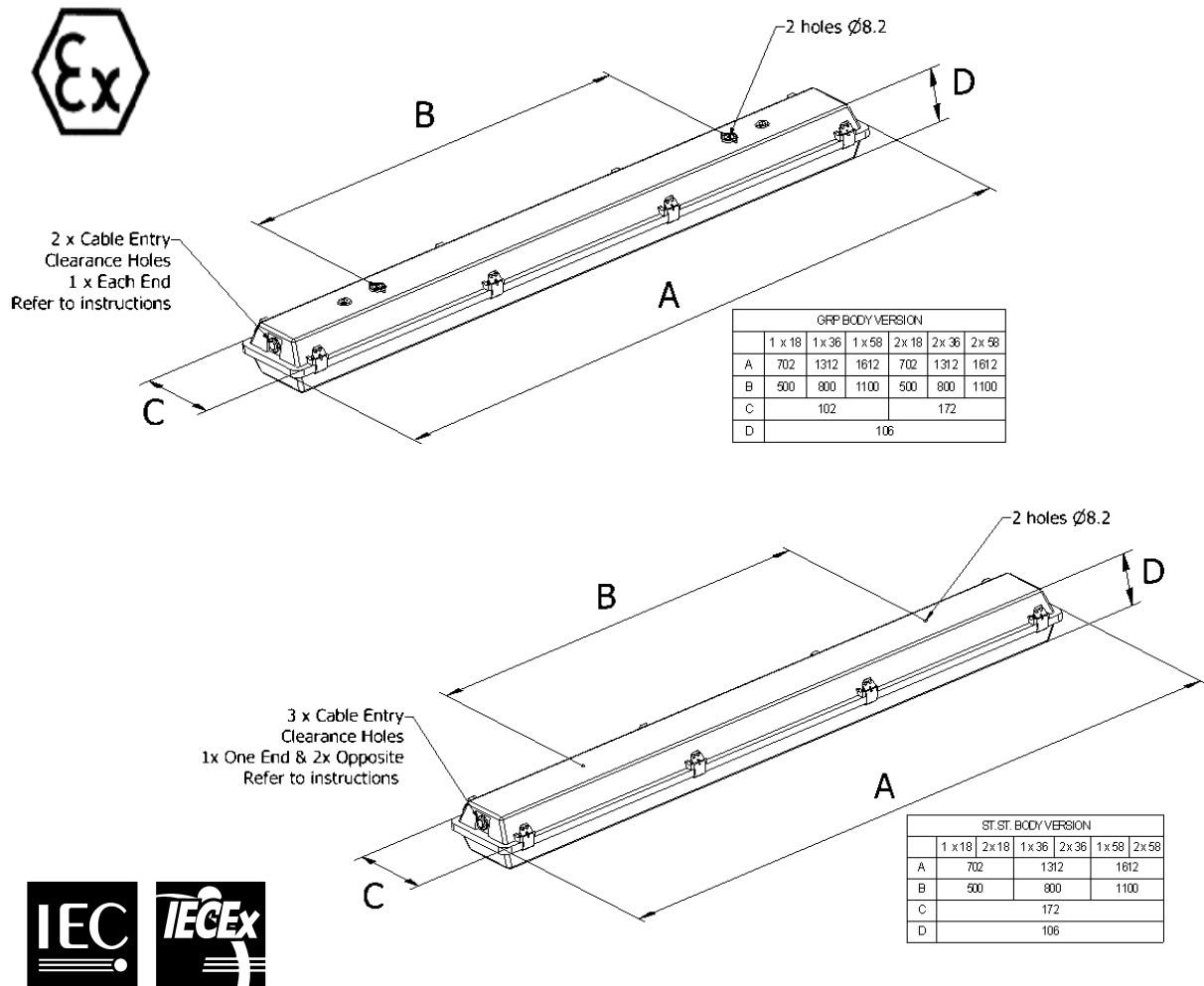

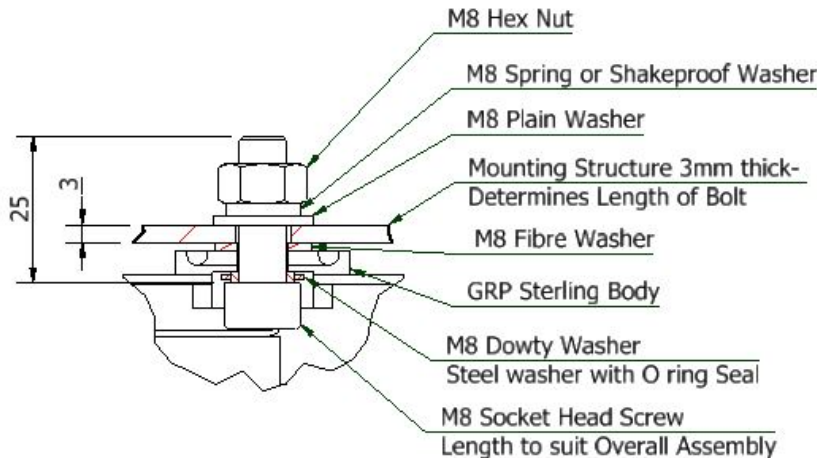

Section Thru Mounting Holes  
Typical Arrangement of Sealing Washers

<b>0.0 Specification</b>	
Type Of Protection	Ex nA, (non-sparking). Ex tD,
Protection Standards	IEC 60079-0, EN 60079-15, EN 61241-0, EN 61241-1
Area Classification	Zone 2 areas to EN 60079-10-1, Zone 21 and 22 areas to EN 60079-10-2.
Installation	EN 60079-14
Certificate	Type Examination Certificate Sira06ATEX4348X IECEX Certificate of Conformity IECEX SIR 06.0108X
Equipment Coding	Ex nA II T* Ex tD A21 or A22 IP6X T85°C (T* and amb values see tables below for details)
ATEX Coding	Ⓜ II 3 GD
Ingress Protection	IP65 to EN 60529
CE Mark	<p>The CE marking of this product applies to "The Electrical Equipment (Safety) Regulations 2006", "The Electromagnetic Compatibility Regulations 2004", the "Waste Electrical and Electronic Equipment Regulations 2006" and the "Equipment and Protective Systems intended for use in Explosive Atmospheres Regulations 1996". [This legislation is the equivalent in UK law of EU directives 2014/35/EU, 2014/30/EU, 2012/19/EU and 2014/34/EU respectively].</p> <p>The Equipment is declared to meet the provisions of the ATEX directive (2014/34/EU) by reason of the Type Examination and compliance with the Essential Health and Safety Requirements.</p> <p>M Poutney Technical Manager</p>

**SPECIAL CONDITIONS FOR SAFE USE**

The Luminaire shall only be installed where there is a low risk of mechanical damage. When refitting the diffuser, the fixing clamps are to be re-secured with the original or replacement self tapping screws.

The Luminaires are to be fitted with suitably certified cable glands and blanking devices maintaining with the enclosure an ingress protection rating minimum of IP54 (non-combustible dusts) or IP64 (combustible dusts).

Fasteners through the enclosure used for mounting purpose shall be fitted with appropriate sealing washers to maintain the ingress protection rating of the enclosure.



**Luminaire is supplied with Battery plug/Socket disconnected, just prior to switching power on connect battery plug and socket.**

## 1.0 Introduction – Zone 2 & Zone 22 Ex nA Fluorescent Luminaire

### General

The type of protection is Ex nA. The Zone 2 & Zone 22 series Ex nA fluorescent luminaires are surface mounted or suspended, utilising the two holes on the base of the body. They are mainly used in harsh environments, and are constructed using a corrosion resistant glass reinforced polyester or stainless steel body, attached to an injection moulded polycarbonate diffuser by stainless steel toggle clips. The control gear and lampholders are mounted on a removable tray that for maintenance purposes has hanging straps.

**Note:** *The ratings are listed in TABLES A – E.*

### 1.1 Application

The luminaire is designed to be safe in normal operation. The luminaire should not be used where there are environmental, vibration or shock conditions above the normal for fixed installations. The gaskets should not be exposed to hydrocarbons in liquid or high concentration vapour states.

The luminaire is suitable for applications where Category 3 apparatus can be used. The type examination does not address suitability for portable applications.

## 2.0 Storage

Luminaires are to be stored in cool dry conditions preventing ingress of moisture and condensation. Any specific instructions concerning emergency luminaires must be complied with.

Battery packs in storage should be cycled charged/discharged/charged every 9 months, as per instructions below. **Always disconnect battery plug and socket for storage.**

Any specific instructions concerning emergency luminaires must be complied with.

(Warning: Battery packs not cycled and stored for a year may not be recoverable)

## 3.0 Installation and Safety

### 3.1 General

There are no health hazards associated with this product whilst in normal use. However, care should be exercised during the following operations. Installation should be carried out in accordance with relevant EN / IEC standard or the local hazardous area code of practice, whichever is appropriate.

These instructions should be read carefully before attempting to install the luminaire. Copies of these instructions should be held in a safe place for future reference.

It is the responsibility of the installer to ensure that the apparatus selected is fit for its intended purpose and that the installation, operation and maintenance of the apparatus complies with regulations, standards or codes of practice applicable.

Any specific installation instructions must be referred to. In the UK, the requirements of the Health and Safety at Work Act must be met and electrical work associated with this product must be in accordance with the "Manual Handling Operations Regulations" and "Electricity at Works Regulations 1989". Your attention is drawn to the paragraphs (i) 'Electrical Supplies', (ii) 'Electrical Fault Finding and Replacement' and (iii) 'Inspection and Maintenance'. The luminaires are Class 1 and should be effectively earthed.

The luminaires are quite heavy and suitable means of handling on installation must be provided.

Certification details on the rating plate must be verified against the application requirements before installation.

The information in this leaflet is correct at the time of publication. The manufacturer reserves the right to make specification changes as required.

The GRP body & polycarbonate diffuser presents a potential source of ignition by **electrostatic electricity**. The diffuser should only be cleaned using a damp cloth. The luminaire should not be mounted very near to any probable location of fast moving stream of dry air, steam etc. which could generate a propagating brush static discharge

### 3.1.1 Use in Combustible Dust Atmospheres – Zone 22

Where the equipment is used in ignitable dust atmospheres reference must be made to the selection and installation standards in order that the equipment is used correctly. In particular this applies to the de-rating of surface temperature for use where dust clouds may be present. Dust layers should not be allowed to accumulate



on the fitting surface and good housekeeping is required for safe operation. Dust in layers has the potential to form ignitable clouds and to burn at lower temperatures.

Self tapping screws are supplied with the luminaire to lock the diffuser clamps. **These must be fitted to maintain the certification.**

Refer to (IEC) EN 60079-10-2 & (IEC) EN 61241-14 for additional details of selection, installation and maintenance.

### 3.1.2 Hybrid Mixtures – Gas plus Dust

Where Hybrid mixtures exist as defined in EN1127 as a potentially explosive atmosphere, consideration should be given to verifying that the maximum surface temperature of the luminaire is below the ignition temperature of the hybrid mixture.

### 3.1.3 Cleaning

The body of the luminaire may be cleaned with a mild solution of household detergent and water, after cleaning the body should be washed and wiped with clean water. The diffuser should not be polished or wiped with a dry cloth, as a risk of explosion due to electrostatic discharge may result. Cleaning of the diffuser with any chemical or hydrocarbon solvent based cleaner may result in severe damage.

### 3.1.4 Aggressive substances

If the equipment is likely to come into contact with aggressive substances, then it is the responsibility of the user to take suitable precautions that prevent it from being adversely affected, thus ensuring that the type of protection provided by the equipment is not compromised.

Aggressive substances: e.g. acidic liquids or gases that may attack metals, or solvents that may affect polymeric materials.

Suitable precautions: e.g. regular checks as part of routine inspections or establishing from the material's data sheets that it is resistant to specific chemicals.

## 3.2 Tools

Suitable spanners for installing cable glands.

3mm flat blade screwdriver. No.1 Pozidrive screwdriver.

Pliers, knife, wire strippers/cutters.

## 3.3 Electrical Supplies

The supply voltage and frequency should be specified when ordering. A maximum voltage variation of +6%/-6% on the nominal is expected. (The safety limit for T rating is +10%). Luminaires should not be operated continuously at more than +6%/-10% of the rated supply voltage of the control gear.

## 3.4 Lamps

The lamps used in the range can be T8 bi-pin fluorescent with G13 cap. Lamp caps are to IEC 60061, lamp dimensions and safety to IEC 61195 and lamp performance to IEC 60081.

## 3.5 Mounting

Luminaires should be installed where access for maintenance is practical and in accordance with any lighting design information provided for the installation. The mounting attitudes are restricted to ceiling, pendant, outreach pole (lamps facing down or horizontally outward) and horizontal wall mount. The luminaire is mounted using the DIA 8.2mm mounting holes on the rear of the body.

On mounting the luminaire by using the holes, it is the responsibility of the user to ensure that an adequate seal is made, to maintain the desired IP rating with a minimum of IP54 or IP64 for conductive dust. Sealing Washers are provided.

## 3.6 Cabling and Cable Glands

### 3.6.1 Cables

The GRP models have facility for through wiring but do not have a facility for looping. The metal bodied series have the facility both looping and through wiring.

The temperature conditions of the supply cable entry point are such that 70°C (ordinary PVC) cable can be used. On models where there is no fixed through wiring fitted, but where there is a looping facility on the gear tray, any supply wiring passing through the body must either have a rating of 130°C or have sleeving fitted which has a

130°C rating. 300/500V cable ratings are adequate and no special internal construction is necessary. Where MCB's are used, the type with the higher short time tripping current ratio used for motor starting and lighting should be specified. The standard maximum looping size is 2.5mm<sup>2</sup> with options of 2.5mm<sup>2</sup> through wiring. An internal earth tag can be fitted to the cable gland.

**Note:** Through wiring when used, is subject to a maximum current of 16A.

### 3.6.2 Cable Gland Types

Cable glands for entry into Ex enclosures shall conform to the requirements of EN / IEC 60079-0.

When fitted with any gland to body sealing method and supply cable, must reliably maintain the IP rating of the enclosure with a minimum value of IP54 or IP64 where conductive dusts may be present. Sealing plugs for unused entries should be similarly rated and fitted. DIA 20 cable entry clearance holes suitable for M20 cable glands are standard.

Alternatively, DIA 25 cable entry clearance holes suitable for M25 cable glands may be provided.

### 3.6.3 Earthing

On GRP bodied luminaires, all internal metal parts are earthed through the metal geartray / reflector. The geartray / reflector is earthed via supplied cable to incoming terminal block. Metal bodied luminaires have additional earth bond from incoming terminal block to the luminaire body.

It is the installer's responsibility to ensure proper earth supply to the luminaire and to ensure any metal cable glands are properly earthed. Cable gland earth kits are available from the manufacturer.

### 3.6.4 Cabling

Access for cabling is via diffuser cover; care is to be taken, as there is no suspension of diffuser cover. The diffuser clip screws are removed and the diffuser clips are undone and the diffuser laid aside. The gear tray is dropped down after unclipping the steel mounting clips. The tray can be removed by undoing the spring clips on the suspension cables. Any earth tag connections should be fitted.

The connecting terminals are identified and the conductors should be bared back so that they make full contact in the terminals, but the bare conductor should not be more than 1mm beyond the terminal. Unused terminal screws should be tightened. The cores must be identified by polarity and connected in accordance with the terminal markings. Before re-fitting the cover, a final check on the correctness of connections should be made.

## 3.7 Fitting Lamps

Before opening the diffuser cover, ensure that the luminaire is isolated from mains supply. Access for re-lamping is via the diffuser cover; care is to be taken, as there is no suspension facility for the diffuser cover.

**Note:** The diffuser cover orientation on removal as the diffuser cover must be refitted in its original orientation to maintain the IP rating.

Make sure that the correct lamp is selected. The lampholders are tombstone type, place the lamp in the lampholder and rotate 90° in lampholder. When inserting new lamps ensure pins and lampholder connection is centralised. Replace diffuser cover in the correct orientation & snap diffuser clips into place.

**IMPORTANT** - In Zone 22 areas, the supplied the locking screws (No.6 x 5/16" (3.5mm x 8) Stainless Steel Self tapping Pozidrive) must be fitted into the diffuser clips.

### 3.7.1 Fused Terminal Blocks

When a fused terminal block has been fitted, it is essential that the metal clamp supplied retains the fuse holder.

## 3.8 Inspection and Maintenance

Visual inspection should be carried out at a minimum of 12 monthly intervals and more frequently if conditions are severe. The time between lamp changes could be very infrequent and this is too long a period without inspection.



**3.8.1 Routine Examination**

The equipment must be de-energised before opening. Individual organisations will have their own procedures. What follows are guidelines based on IEC 60079-17 and on our experience:

- 1 Ensure lamps are lit when energised by mains supply.
- 2 Visually check diffuser cover for damage. This should only be cleaned using a damp cloth to avoid static and only use recommended detergents for polycarbonate. If the polycarbonate is discoloured or damaged, a new diffuser cover must be fitted.
- 3 When de-energised and left to cool, there should be no significant sign of internal moisture. If there are any signs of water ingress, the luminaire should be opened up, dried and any likely ingress points eliminated by re-gasketing or other replacements. If the diffuser cover is removed, its orientation must be noted and it must be refitted in the original orientation.
- 4 Check cable gland for tightness and nip up if required.
- 5 Check any external and internal earths.
- 6 Check all terminations are firmly screwed down, tighten if necessary.
- 7 Check clips visually for any damage and replace, if necessary.
- 8 If it has been suspected that the luminaire has suffered mechanical damage, a stringent workshop check on all components should be made. All components can be removed from the luminaire for inspection.
- 9 Avoid the build up of dust layers by regular cleaning and again clean only using a damp cloth.

**3.8.2 Routine Testing of Emergency Lighting Functions**

Users should ensure that the performance of emergency lighting remains adequate for their purposes by conducting periodic tests and recording the results. Requirements will differ between countries, applications and organisations. In the United Kingdom BS 5266 Pt1 gives guidance on testing.

**3.8.3 Self Test Emergency Lighting Functions**

For luminaires with Auto test (Option / BMT) built in, the following procedure and displays apply.

Monitoring Function Indication					
Remarks	System Status	Green LED	Red LED	Sound	Emergency Lamp
COMMISSIONING	NORMAL	SLOW FLASHING (Once every 2 seconds)	OFF	OFF	OFF *
STANDBY	NORMAL	SLOW FLASHING (once every 10 seconds)	OFF	OFF	OFF*
DURATION TEST	NORMAL	SLOW FLASHING (Once every 2 seconds)	OFF	OFF	ON
FUNCTION TEST	NORMAL	FAST FLASHING	OFF	OFF	ON
EMERGENCY MODE	NORMAL	OFF	OFF	OFF	ON
LAMP FAILURE	FAULT	OFF	FAST FLASHING	3 PULSE TONE	OFF
BATTERY CHARGE FAILURE	FAULT	OFF	SLOW FLASHING	3 PULSE TONE	OFF
BATTERY DURATION FAILURE	FAULT	OFF	SLOW FLASHING	3 PULSE TONE	OFF
CIRCUIT FAILURE	FAULT	OFF	FAST FLASHING	PERMANENT PULSE TONE	OFF

\* Emergency Lamp may be on if mains is connected.

The unit is reset by forcing a test by switching it off twice in 10 seconds.

Test duration:

- forced test: 5 seconds
- monthly test: 5 minutes
- 6 month test: 1 hour
- 12 month test: 3 hour

### 3.9 Electrical Fault Finding and Replacement (Refer EN / IEC 60079-19)

The supply must be isolated before opening the luminaire.

Any live fault finding must be done by a competent electrician and, if carried out with luminaire in place, under a permit to work. Where the control gear is copper and iron, the fitting can be tested for continuity of connections.

When electronic high frequency gear is fitted do not megger.

If lamps go out repeatedly, and replacement lamps do not work or expected life is reduced, where applicable replacement starters should be tried. However, if this does not correct the fault the control gear should be returned for replacement/testing. The High frequency ballast will cut out if lamps are defective. The High frequency ballasts are approved components. On re-assembly, all faulty/damaged wiring should be replaced and connections checked.

#### 3.9.1 Battery Check and Replacement (Refer EN / IEC 60079-19)

Do not open luminaire when a hazardous atmosphere is present. Isolate before opening. The battery is detached at the plug and socket. Remove the two screws to release the battery. Re-assembly is in reverse order.

**Important :** *Although the battery pack is fitted with a polarised plug and socket to prevent accidental shorting, Care must be taken not to short the leads together as this can cause sparking which, in turn, could lead to a fire.*

The emergency duration is 3 hours for the 18W, 36W and the 58W. This is in accordance with IEC 60598 2-22. The battery must be replaced when the duration is not acceptable.

Protect the batteries from water ingress and mechanical damage then transport from the hazardous area as soon as practical. Take care to fully discharge batteries before transporting or otherwise ensure that there can be no release of stored energy in transit.

#### 3.9.2 Checking of Battery separately

If the battery is to be checked separately, it should be charged using a **constant current charger** at 200/400mA for 30/15 hours for the 4Ah. Discharge measurement is not easy as the current is proportional to the voltage for resistance loads, so it has to be averaged. Discharge the battery at 1 to 2A and multiply current by time. Do not discharge below 1 volt per cell, which is 5V. The capacity should be 75% or more of normal.

### 4.0 Overhaul (Refer EN / IEC 60079-19)

Components to be incorporated into or used as replacement parts of the equipment shall be fitted by suitably trained personnel and other than the fuse are to be purchased from the manufacturer as to ensure that certification is not invalidated. The certification of this equipment relies upon the following materials used in its construction: Glass re-enforced polyester body, clear polycarbonate diffuser, stainless steel clips and EPDM rubber gasket.

The unit is largely made of materials that are very corrosion resistant. This allows the unit to be completely stripped, cleaned, then re-built with new electrical parts as required. The internal wiring is 0.8mm<sup>2</sup> solid core, HTPVC insulated. All the spares required are available. Please state the model number and lamp details.

The seal is between the polycarbonate diffuser and the base. The diffuser is retained by stainless steel clips. If the sealing gasket has deteriorated by softening or permanent set, a new sealing gasket should be fitted, which can be obtained from the manufacturer. To fit this, care is needed, the old gasket should be removed and remaining adhesive scraped off. The gasket is fixed in place to the body with a small amount of silicone RTV.

It is the end users responsibility to ensure the materials of construction and the product certification as detailed on the product label is suitable for intended installation location.

### 5.0 Fuse Ratings

With the availability of MCB's with a wide range of characteristics, the individual engineer can make a better judgement of what is required. Use MCB's suitable for inrush currents to reduce ratings. Where MCB's are used,

the type with the higher short time tripping current ratio used for motor starting and lighting should be specified. The inrush current can be calculated where circuit conditions are known. The inrush currents can be obtained from the manufacturer.

The fuse ratings for fluorescent lamp circuits need to take account of three components of circuit current. Where PFC capacitors are fitted, the current inrush can be up to 25 x the rated capacitor current and last 1-2milli seconds The inrush current can be calculated where circuit conditions are known. For luminaires the nominal capacitor current will probably be the determining factor, 0.076A per µF at 240V, 50Hz (adjust for other supply volts by multiplication, x 6/5 for 60Hz). For HBC fuses use 1.5 x normal capacitor current. All calculations must satisfy wiring regulations.

**Note:** Line currents for 240V, 50Hz are as indicated in Table F.

**6.0 Disposal of Material**

Any disposal must satisfy the requirements of the WEEE directive [2012/19/EU] and therefore must not be treated as commercial waste. The unit is made from combustible materials. The capacitor is of the dry film type and does not contain PCB's. The control gear contains plastic parts and polyester resin. The ignitor contains electronic components and synthetic resins. All electrical components and the body parts may give off noxious fumes if incinerated. Take care to render these fumes harmless or avoid inhalation. Any local regulations concerning disposal must be complied with.

**6.1 Lamps**

Fluorescent lamps in modest quantities are not "special waste". The outer envelope should be broken in a container to avoid possible injury from fragmentation. Avoid inhaling dust. This applies to the UK; there may be other regulations on disposal operating in other countries.

**Important:** Do not incinerate lamps.

**6.2 Battery Disposal**

Nickel cadmium batteries are defined as 'controlled waste' under the hazardous waste regulations and the user needs to observe a 'duty of care'.

Batteries can be returned to the manufacturers for re-cycling. They must be stored and transported safely and any necessary pollution control forms completed prior to transportation. Take care to fully discharge batteries before transporting or otherwise ensure that there can be no release of stored energy in transit. For further details refer to Technical Department.



To comply with the Waste Electrical and Electronic Equipment directive 2012/19/EU the apparatus cannot be classified as commercial waste and as such must be disposed of or recycled in such a manner as to reduce the environmental impact.

**Tables A/B/C/D/E/F**

TABLE A - SCHEDULE – HF GEAR – NON EMERGENCY – 120 to 240V								
Note: for Dust Ratings Refer to Max Surface Temperatures.								
LAMP	BODY TYPE	BODY MAT'L	NOM VOLTS	BALLAST	INVERTER	AMBIENT TEMP	T RATING	MAX SURFACE TEMP (DUST)
1 X 18W	SINGLE	GRP	120 – 240 With HF Ballast	1 X 18W	N/A	-20°C ≤ Ta ≤ +45°C	T4	85°C
	TWIN	GRP & ST.ST.				-20°C ≤ Ta ≤ +45°C		
2 X 18W	TWIN	GRP & ST.ST.		2 X 18W		-20°C ≤ Ta ≤ +45°C		
1 X 36W	SINGLE	GRP		1 x 36W		-20°C ≤ Ta ≤ +45°C		
	TWIN	GRP & ST.ST.				-20°C ≤ Ta ≤ +45°C		
2 X 36W	TWIN	GRP &		2 x 36W		-20°C ≤ Ta ≤ +45°C		





1 X 58W	SINGLE	GRP	120V with Step-up Transformer And 240V HF Ballast	1 x 58W	N/A	-20°C ≤ Ta ≤ +45°C	T4	85°C
	TWIN	GRP				-20°C ≤ Ta ≤ +45°C		
	TWIN	ST.ST.				-20°C ≤ Ta ≤ +35°C		
2 X 58W	TWIN	GRP		2 x 58W		-20°C ≤ Ta ≤ +45°C		
	TWIN	ST.ST.				-20°C ≤ Ta ≤ +45°C		
1 X 18W	SINGLE	GRP		120V with Step-up Transformer And 240V HF Ballast		1 X 18W		
	TWIN	GRP & ST.ST.	-20°C ≤ Ta ≤ +30°C					
2 X 18W	TWIN	GRP & ST.ST.	2 x 18W		-20°C ≤ Ta ≤ +30°C			
	1 X 36W	SINGLE			GRP	1 x 36W	-20°C ≤ Ta ≤ +30°C	
TWIN		GRP & ST.ST.	-20°C ≤ Ta ≤ +30°C					
2 X 36W	TWIN	GRP & ST.ST.	2 x 36W		-20°C ≤ Ta ≤ +30°C			
	1 X 58W	SINGLE			GRP	1 x 58W	-20°C ≤ Ta ≤ +30°C	
TWIN		GRP	-20°C ≤ Ta ≤ +30°C					
TWIN		ST.ST.	-20°C ≤ Ta ≤ +20°C					
2 X 58W	TWIN	GRP	2 x 58W		-20°C ≤ Ta ≤ +30°C			
	TWIN	ST.ST.			-20°C ≤ Ta ≤ +30°C			

**TABLE B - SCHEDULE – HF GEAR – EMERGENCY – 120 to 240V**

Note: for Dust Ratings Refer to Max Surface Temperatures.

LAMP	BODY TYPE	BODY MAT'L	NOM VOLT S	BALLAS T	INVERTE R	AMBIENT TEMP	T RATIN G	MAX SURFAC E TEMP (DUST)				
1 X 18W	TWIN	GRP or ST.ST.	120V – 240V With HF Ballast	1 X 18W	VL111 SIRA00ATEX4215U	-20°C ≤ Ta ≤ +40°C	T4	85°C				
2 X 18W				2 X 18W		-20°C ≤ Ta ≤ +40°C						
1 X 36W	TWIN	GRP or ST.ST.		1 X 36W		-20°C ≤ Ta ≤ +40°C						
2 X 36W				2 x 36W		-20°C ≤ Ta ≤ +40°C						
1 X 58W	TWIN	GRP		1 x 58W		-20°C ≤ Ta ≤ +40°C						
		ST.ST.				-20°C ≤ Ta ≤ +30°C						
2 X 58W	TWIN	GRP		2 x 58W		-20°C ≤ Ta ≤ +40°C						
		ST.ST.				-20°C ≤ Ta ≤ +40°C						
1 X 18W	TWIN	GRP or ST.ST.		120V with Step-up Transformer And 240V HF Ballast		1 x 18W			MVL111 SIRA00ATEX4215U	-20°C ≤ Ta ≤ +30°C	T4	85°C
2 X 18W						2 x 18W				-20°C ≤ Ta ≤ +30°C		
1 X 36W	TWIN	GRP or ST.ST.				1 x 36W				-20°C ≤ Ta ≤ +30°C		
2 X 36W						2 x 36W				-20°C ≤ Ta ≤ +30°C		



1 X 58W	TWIN	GRP		1 x 58W		$-20^{\circ}\text{C} \leq T_a \leq +30^{\circ}\text{C}$		
		ST.ST.				$-20^{\circ}\text{C} \leq T_a \leq +20^{\circ}\text{C}$		
2 X 58W	TWIN	GRP		2 x 58W		$-20^{\circ}\text{C} \leq T_a \leq +30^{\circ}\text{C}$		

<b>TABLE D - SCHEDULE – HF GEAR – NON EMERGENCY – 120 to 254V</b>								
Note: for Dust Ratings Refer to Max Surface Temperatures.								
LAMP	BODY TYPE	BODY MAT'L	NOM VOLT S	BALLAST	INVERTE R	AMBIENT TEMP	T RATING	MAX SURFAC E TEMP (DUST)
1 X 18W	SINGLE	GRP	120 – 254 With HF Ballast	1 X 18W	N/A	$-20^{\circ}\text{C} \leq T_a \leq +35^{\circ}\text{C}$	T4	85°C
	TWIN	GRP & ST.ST.				$-20^{\circ}\text{C} \leq T_a \leq +35^{\circ}\text{C}$		
2 X 18W	TWIN	GRP & ST.ST.		2 X 18W		$-20^{\circ}\text{C} \leq T_a \leq +35^{\circ}\text{C}$		
1 X 36W	SINGLE	GRP		1 x 36W		$-20^{\circ}\text{C} \leq T_a \leq +35^{\circ}\text{C}$		
	TWIN	GRP & ST.ST.				$-20^{\circ}\text{C} \leq T_a \leq +35^{\circ}\text{C}$		
2 X 36W	TWIN	GRP & ST.ST.		2 x 36W		$-20^{\circ}\text{C} \leq T_a \leq +35^{\circ}\text{C}$		
1 X 58W	SINGLE	GRP		1 x 58W		$-20^{\circ}\text{C} \leq T_a \leq +35^{\circ}\text{C}$		
	TWIN	GRP				$-20^{\circ}\text{C} \leq T_a \leq +35^{\circ}\text{C}$		
	TWIN	ST.ST.				$-20^{\circ}\text{C} \leq T_a \leq +25^{\circ}\text{C}$		
2 X 58W	TWIN	GRP		2 x 58W		$-20^{\circ}\text{C} \leq T_a \leq +35^{\circ}\text{C}$		
	TWIN	ST.ST.	$-20^{\circ}\text{C} \leq T_a \leq +35^{\circ}\text{C}$					



TABLE E - SCHEDULE – HF GEAR – EMERGENCY – 120 to 254V								
Note: for Dust Ratings Refer to Max Surface Temperatures.								
LAMP	BODY TYPE	BODY MAT'L	NOM VOLT S	BALLAS T	INVERTE R	AMBIENT TEMP	T RATIN G	MAX SURFACE TEMP (DUST)
1 X 18W	TWIN	GRP or ST.ST.	120V – 254V With HF Ballast	1 X 18W	VL111 SIRA00ATEX4215U	$-20^{\circ}\text{C} \leq T_a \leq +35^{\circ}\text{C}$	T4	85°C
2 X 18W				2 X 18W		$-20^{\circ}\text{C} \leq T_a \leq +35^{\circ}\text{C}$		
1 X 36W	TWIN	GRP or ST.ST.		1 X 36W		$-20^{\circ}\text{C} \leq T_a \leq +35^{\circ}\text{C}$		
2 X 36W				2 x 36W		$-20^{\circ}\text{C} \leq T_a \leq +35^{\circ}\text{C}$		
1 X 58W	TWIN	GRP		1 x 58W		$-20^{\circ}\text{C} \leq T_a \leq +35^{\circ}\text{C}$		
		ST.ST.				$-20^{\circ}\text{C} \leq T_a \leq +25^{\circ}\text{C}$		
2 X 58W	TWIN	GRP		2 x 58W		$-20^{\circ}\text{C} \leq T_a \leq +35^{\circ}\text{C}$		
		ST.ST.				$-20^{\circ}\text{C} \leq T_a \leq +35^{\circ}\text{C}$		

Table F - Series Circuit.					
No. Off Lamp	Gear Type	Lamp W	Nominal Circuit Power W	PFC $\mu\text{f}$	Line Current
1	HF	18	20		0.09
2		18	38		0.17
1		36	36		0.16
2		36	72		0.32
1		58	56		0.25
2		58	107		0.49

**Typical Twin Lamp HF Wiring Diagram**

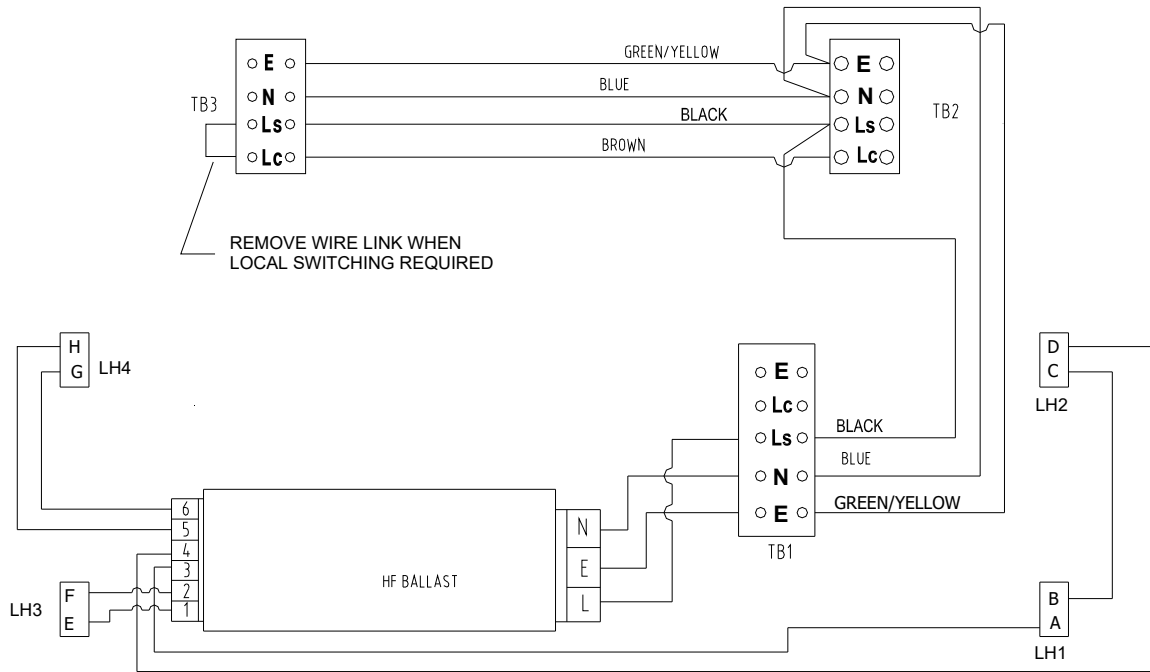

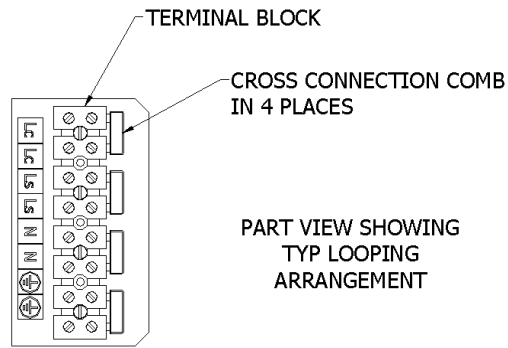

**Typical Twin Lamp HF Wiring Diagram**









**Chalmit Lighting is a leading supplier of Hazardous Area lighting products**

	<b>CHALMIT LIGHTING</b> PO Box 5575 Glasgow, G52 9AP Scotland	
Telephone: +44 (0) 141 882 5555 Fax: +44 (0) 141 883 3704 Email: <a href="mailto:info@chalmit.com">info@chalmit.com</a> Web: <a href="http://www.chalmit.com">www.chalmit.com</a>	Registered No: 669157 Registered Office: Cannon Place 78 Cannon Street London EC4N 6AF UK	

**For technical support, please contact: [techsupport@chalmit.com](mailto:techsupport@chalmit.com)**

Note: Chalmit Lighting reserves the right to amend characteristics of our products and all data is for guidance only.

	<b>EU-Declaration of conformity</b>		
	<b>UE-Déclaration de conformité</b>		
	<b>EU-Konformitätserklärung</b>		
Manufacturer	Chalmit	Address	388 Hillington Road, Glasgow. G52 4BL Scotland UK
Product	Sterling II or Sterling II Emergency		
Type Examination Certificate	Sira 06ATEX4348X		
Notified Body	CSA Group Netherlands B.V. 2813		
ATEX Coding	 II 3GD or II 2D	ATEX Classification	Group II Category 3 GD or 2D
Equipment Coding	Ex nA II T3 or T4. Ex tD A21 or A22 IP6X T85°C		
Ingress Protection	IP65		
The technical basis, with respect to equivalence of			
La base technique, en ce qui concerne l'équivalence de			
Die technische Grundlage hinsichtlich der Normen			
Protection Standards EN 60079-0, EN 60079-15, EN 61241-0, EN 61241-1			
Area Classification EN 60079-10-1, EN 60079-10-2.			
of compliance with the EHSRs is valid as there are no changes which materially affect the state of technological progress of the product.			
en conformité avec les EESS est valide puisqu'il n'y a aucun changement qui affecte matériellement l'état de l'évolution technologique du produit.			
zur Erfüllung der GSGA ist gegeben, da keine Änderungen erfolgt sind, die einen Einfluss auf den technischen Stand des Produkts haben.			
Terms of the directive:		Standard & Date Certified to	Standards Date Declared to
Prescription de la directive:		Standard & date certifiée à	Normes date Déclaré
Bestimmungen der Richtlinie:		Standard & Datum Zertifiziert nach	Standards Datum erklärt
2014/34/EU	Equipment and protective systems intended for use in potentially explosive atmospheres.	EN 60079-0: 2006 EN 60079-15: 2005	2012 2010
2014/34/UE	Appareils et les systèmes de protection destinés à être utilisés en atmosphères potentiellement explosibles.	EN 61241-0: 2006 EN 61241-1: 2004	EN 60079-0: 2012 EN 60075-31: 2014
2014/34/EU	Geräte und Schutzsysteme zur bestimmungsgemäßen Verwendung in explosionsfähigen Bereichen.		
2014/30/EU	Electromagnetic compatibility	EN 55015 : 2013	
2014/30/UE	Compatibilité électromagnétique	EN 61547 : 2009	
2014/30/EU	Elektromagnetische Verträglichkeit	EN 61000-3-2 : 2014	
2014/35/EU	Low voltage equipment	EN 60598-1 : 2015	
2014/35/UE	Équipements électriques à bas voltage	EN 60598-2-5 : 2015	
2014/35/EU	Niederspannungsgeräte / -systeme	EN 60598-2-22 : 2014 EN 60529 : 1992	
2012/19/EU	Waste of electrical and electronic equipment		
2012/19/UE	Déchets d'équipements électriques et électroniques		
2012/19/EU	Entsorgung der elektrischen und elektronischen Geräte / Systeme		
2011/65/EU	RoHS II Directive		



On behalf of the Chalmit, I declare that, on the date the equipment accompanied by this declaration is placed on the market, the equipment conforms to all technical and regulatory requirements of the above listed directives.

En tant que représentant du fabricant Chalmit, je déclare qu'à la date où les équipements accompagnant cette déclaration sont mis sur le marché, ceux-ci sont conformes à toutes les dispositions réglementaires et techniques des directives énumérées ci-dessus.

Hiermit bestätige ich, im Namen von Chalmit, dass am Tag der Lieferung des Produkts/der Produkte zusammen mit dieser Erklärung das Gerät/die Geräte alle technischen und regulativen Anforderungen der oben aufgeführten Direktiven erfüllt.

Name and Date      Mark Poutney    01/01/2021  
Nom et Date  
Name und Datum

Technical Manager  
Directeur technique  
Technischer Leiter

Quality Assurance Notification by:      **SGS Fimko OY**  
Notification d'assurance qualité par:    **0598**  
Qualitätssicherungsnotifikation durch:

Quality Management System Accreditation:  
Système de Management Qualité Accréditation:  
Qualitätsmanagementsystem Akkreditierung:  
Environmental Management System.  
Système de gestion de l'environnement.  
Umwelt kontroll system.  
**Certificate No./Certificat N°/Zertifikat Nr.**

**ISO 9001**

**ISO 14001**  
by/par/durch  
**Lloyd's Register**  
**LRQ 4005876**